



3" BORE ACCESSORIES



MOUNTING NUTS

Stud Nut

Part Number	Across Flats	Nut Thickness	Nut (Thread)
<u>N24-12</u>	2 1/4"	1/2"	1 1/2-12

Rod Nut

Part Number	Across Flats	Nut Thickness	Nut (Thread)
<u>N08-20</u>	3/4"	5/16"	1/2-20

CB-4895

Clevis Bracket
Material: Steel, bright zinc plated

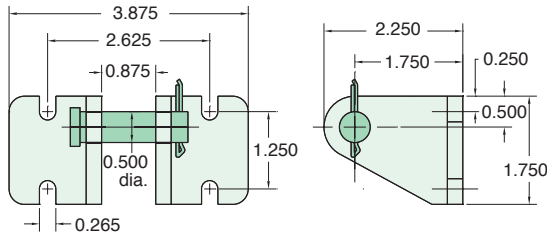

RK-4899

Replaceable Rod Seal
Material: aluminum body

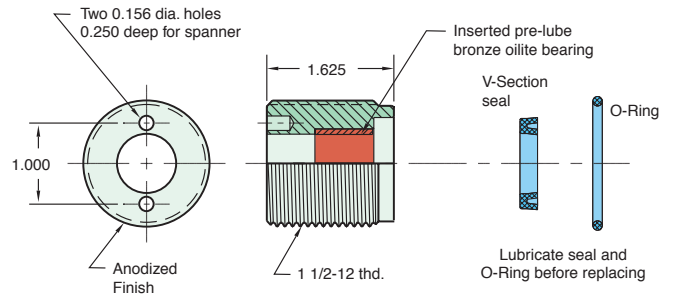

RC-4881

Rod Clevis
Material: Steel, electroless nickel plate

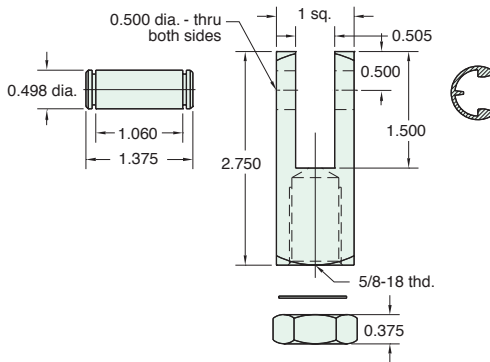

RE-4885

Rod End
Material: Steel, bright zinc plated body

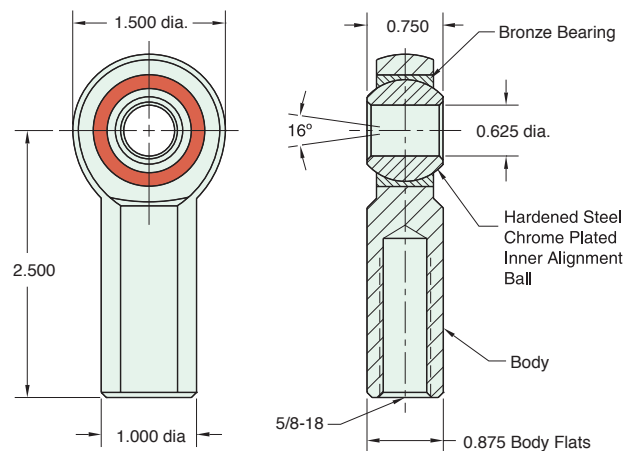

FB-4891

Foot Bracket
Material: Steel, bright zinc plated

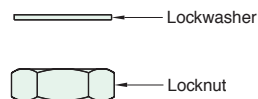
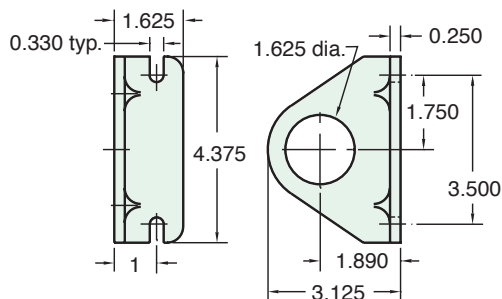

Max. Static Radial Load: 7400 lbs.
Fits Rod Thread Size: 5/8-18